

PRODUCT DATASHEET

MODEL NO

BV03-00032

DESCRIPTION

BRY-W003S-3H-3xE27-BLC-PENDANT LIGHT

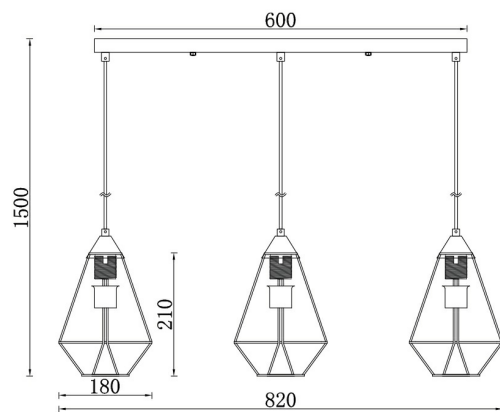

BRAYTRON SRL

Bulaverdul iuliu maniu, Nr.616, Sector 6, 061129, Bucuresti-ROMANIA

info@braytron.com

www.braytron.com

General Characteristics

Model No	:	BV03-00032
Main Family	:	Decorative CLS
Sub Family	:	Wiring
Type	:	Pendant Light
Body Color	:	Black
Lamp Shape	:	N/A
Light Source	:	N/A
Socket	:	3xE27
Warranty	:	2 years
Class	:	Class I
IP	:	IP20

Electrical Characteristics

Voltage	:	220-240V
Material	:	Metal
Frequency	:	50-60 Hz

Package Informations

N.W.	:	1,68 kgs
G.W.	:	2,25 kgs
PCS/CTN	:	1 pcs
Length	:	600 mm
Width	:	170 mm
Height	:	260 mm
EAN	:	5949097734069

Product Characteristics

Wattage	:	Max 3x23 w
---------	---	------------

Dimensions & Weight

Weight	:	1680 gr
--------	---	---------