

Braytron

PRODUCT DATASHEET

MODEL NO BV01-00111

DESCRIPTION BRY-S012R-6H-6xG9-OPL-GLD-PENDANT LIGHT

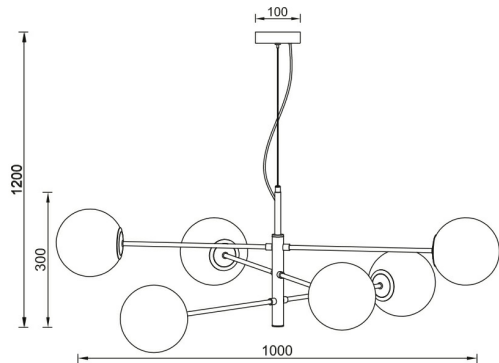

BRAYTRON SRL

Bulavardul Iuliu Maniu, Nr.616, Sector 6, 061129, Bucuresti-ROMANIA

info@braytron.com

www.braytron.com

Page 1-2

General Characteristics

Model No	:	BV01-00111
Main Family	:	Decorative CLS
Sub Family	:	Glass OPL
Type	:	Pendant Light
Body Color	:	Opal+Golden
Lamp Shape	:	N/A
Light Source	:	N/A
Socket	:	6xG9
Warranty	:	2 years
Class	:	Class I
IP	:	IP20

Electrical Characteristics

Voltage	:	220-240V
Material	:	Metal
Frequency	:	50-60 Hz

Package Informations

N.W.	:	2,56 kgs
G.W.	:	3,50 kgs
PCS/CTN	:	1 pcs
Length	:	545 mm
Width	:	470 mm
Height	:	200 mm
EAN	:	5949097735295

Product Characteristics

Wattage	:	Max 6x10 w
---------	---	------------

Dimensions & Weight

Weight	:	2560 gr
--------	---	---------